

Pan-International (2328 TT)

**Igniting new growth engines to
moving up the value chain**



Pan-International

April 2026

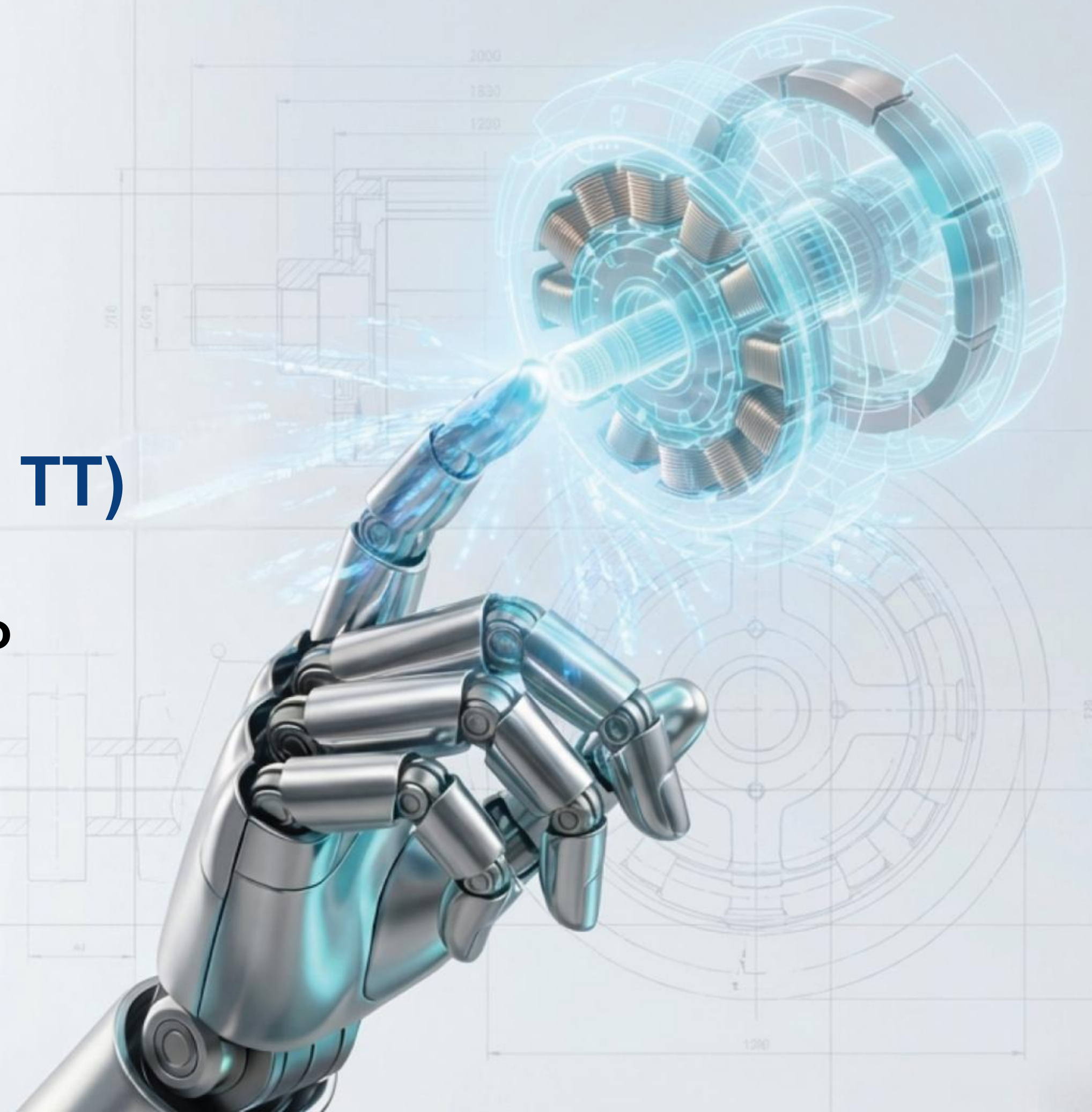

Table of Content

01

Entering humanoid robotics market with next-Gen AFM technologies

02

Pan-International's humanoid robotics strategic roadmap

03

Moving up the value chain via 3S Strategy

04

Strategic objectives and outlook

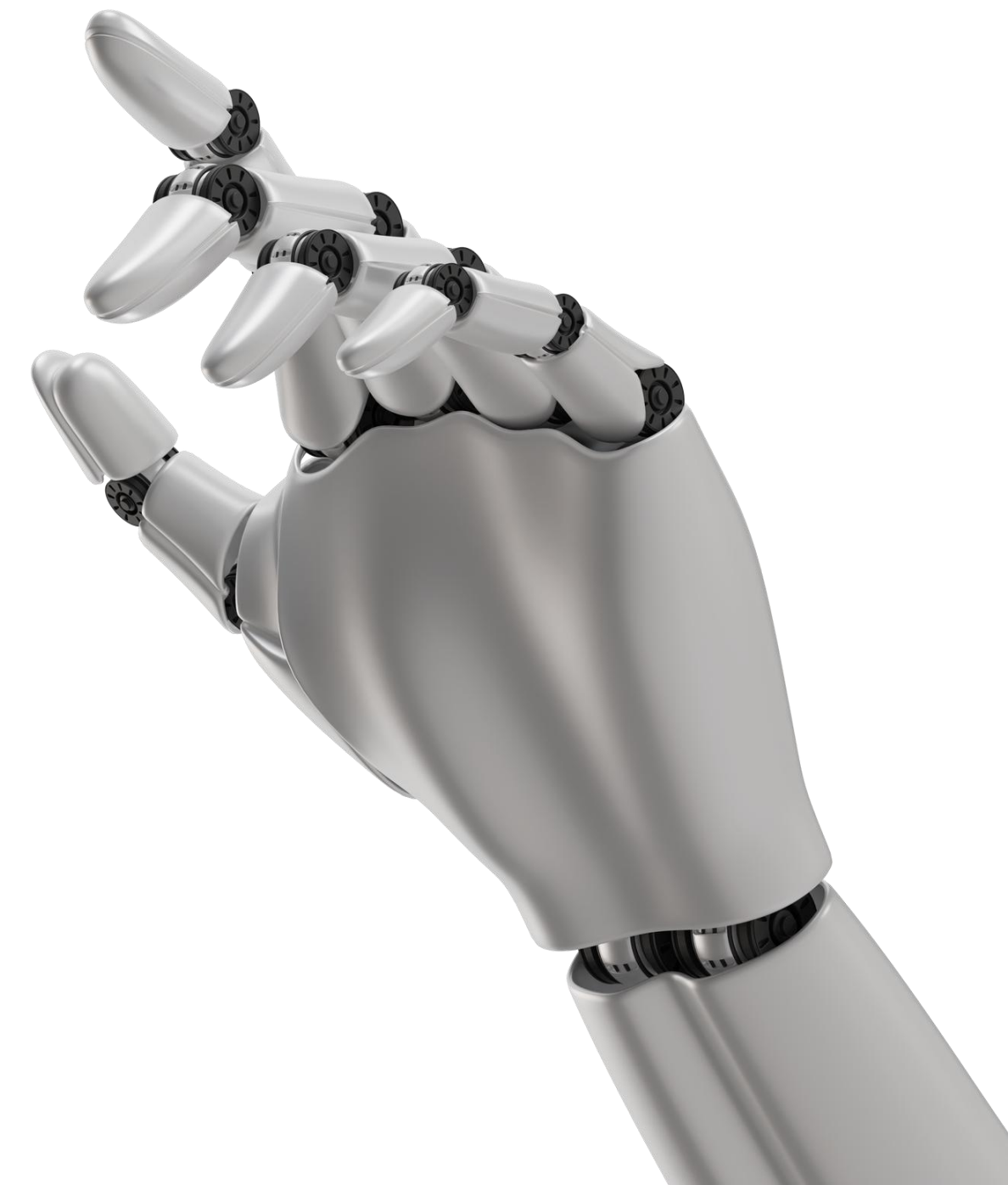

Entering humanoid robotics market with next-Gen AFM technologies

Acquisition of Next-Gen AFM technology

■ Core electromechanical capabilities for humanoid robotics

Pan-International acquired a Belgian Axial Flux Motor (AFM) company Magnax in Jan 2026. This establishes a core competitive advantage for our humanoid robotics business and secures a pivotal position within the broader Foxconn Group robotics development roadmap.

■ Establishing humanoid robotics as a long-term strategic focus

Magnax provides significant technical depth and product scalability. Moving forward, Pan-International will focus on humanoid robotics technologies, particularly the acquisition of core intellectual property for key components.

Key assets acquired in this transaction



Core patents

Encompassing yoke-less stators, dual-rotor structures, and modular thermal design.



R&D talent

A top-tier electromagnetics and mechanical engineering team with a research background from Ghent University, Belgium.



Supply chain access

Leveraging AFM platform technology to gain technical entry into industrial applications and powertrain machinery.

Next-Gen motor technology: Advantages of AFM

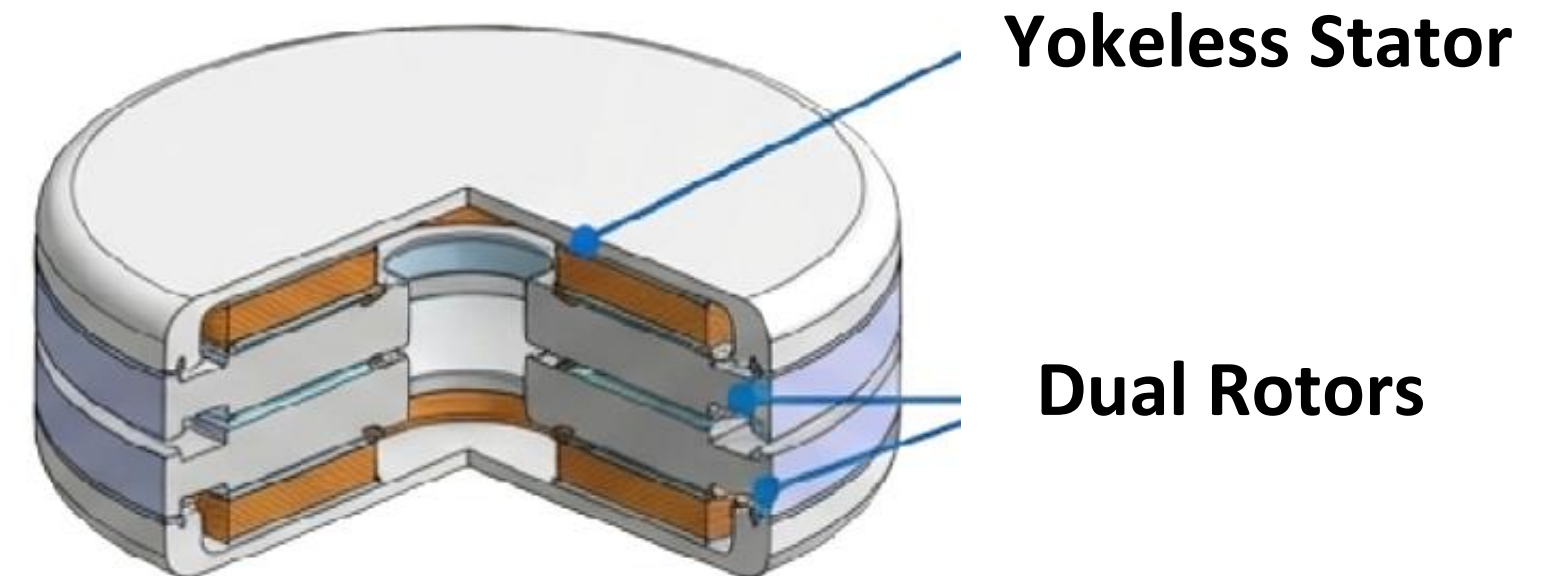
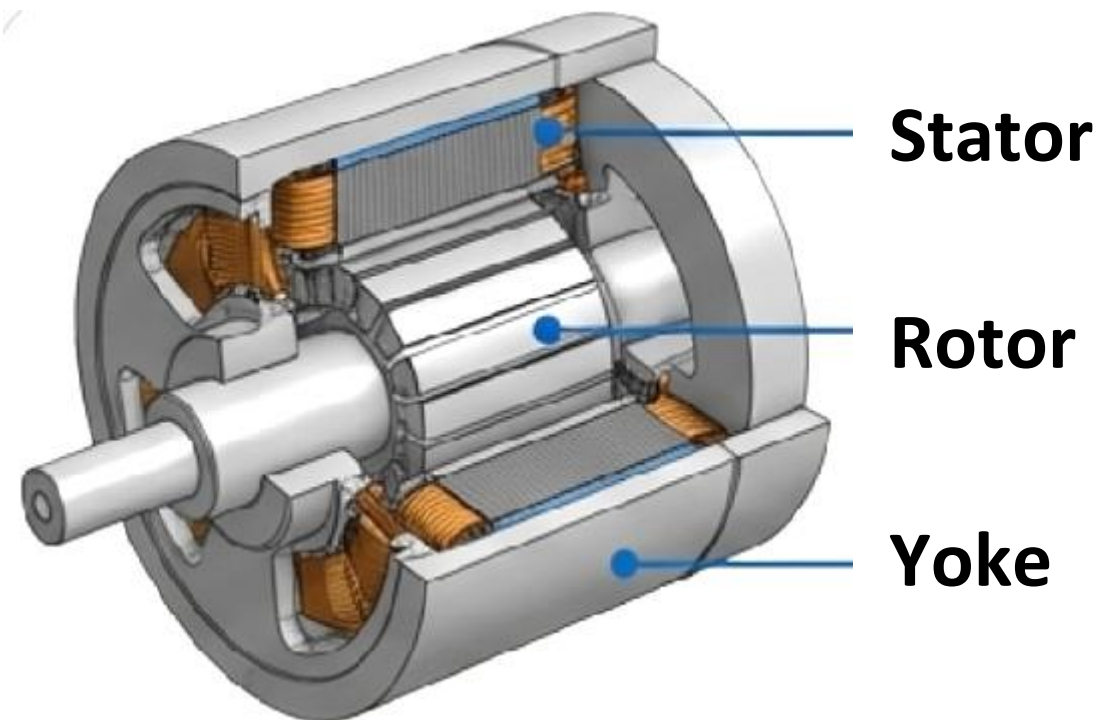

Feature	RFM (Radial flux motor)	AFM (Axial flux motor)
Power density (at equivalent volume)	1x	2-3x
Volume and weight (at equivalent power)	1x	Volume & weight reduced by 1/3
Physical characteristics	Traditional cylindrical shape	"Pancake" architecture; ideal for integration in confined spaces

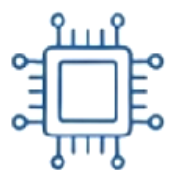

Magnax's high-moat patent portfolio

Core patents cover yoke-less stator design, modular architecture, dual-rotor layout, and advanced cooling systems. These patents cover most viable pathways for AFM Yoke-less technology.

AFM: Optimal solution for humanoid robotics

Joint space constraints

Humanoid joints require extremely high torque within narrow spatial limits. AFM's pancake architecture (thin-profile design) is currently the most ideal technology to meet these demanding form-factor requirements.

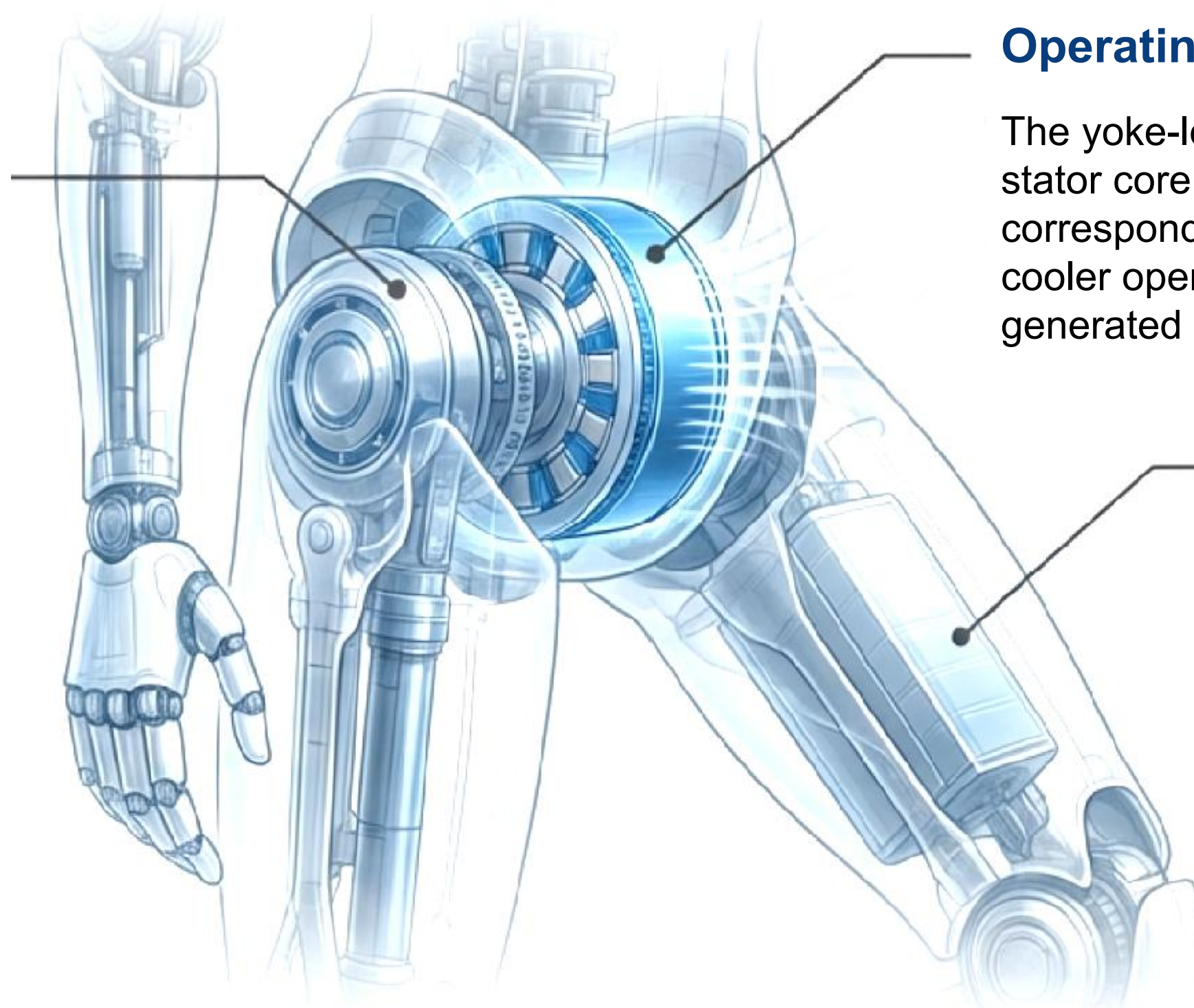

Operating temperature

The yoke-less design significantly reduces stator core mass and eliminates corresponding iron losses. This allows for cooler operation by lowering the heat generated during high-intensity motor cycles.

Endurance and range

The efficiency curve remains above 95% across a broad range of operational speeds. This high efficiency significantly extends the robot's effective operating time and battery life per single charge.

AFM represents the most viable next-generation motor technology roadmap for humanoid robotics joint applications.

The strategic importance of Magnax

■ Platform technology for diversified applications:

AFM is a versatile platform technology that allows Pan-International to expand into Electric Vehicles (EV), Robotics, and Data Center cooling applications.

■ Superior power density & mass-production readiness:

Compared to industry peers, Magnax products offer higher power density and a higher level of maturity for mass production.

■ Defensible patent portfolio:

Magnax's core patents cover yoke-less stator design and cooling systems, effectively covering most feasible technical routes for AFM implementation.

From key components to integrated system modules

Past

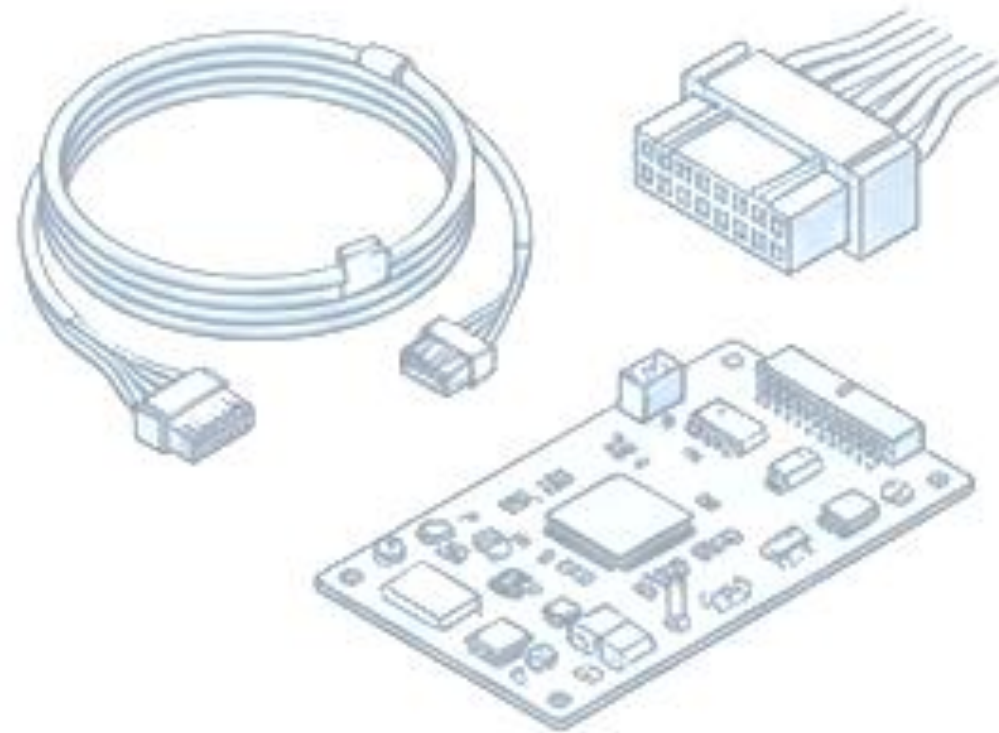

Precision component manufacturer

Post-Magnax integration

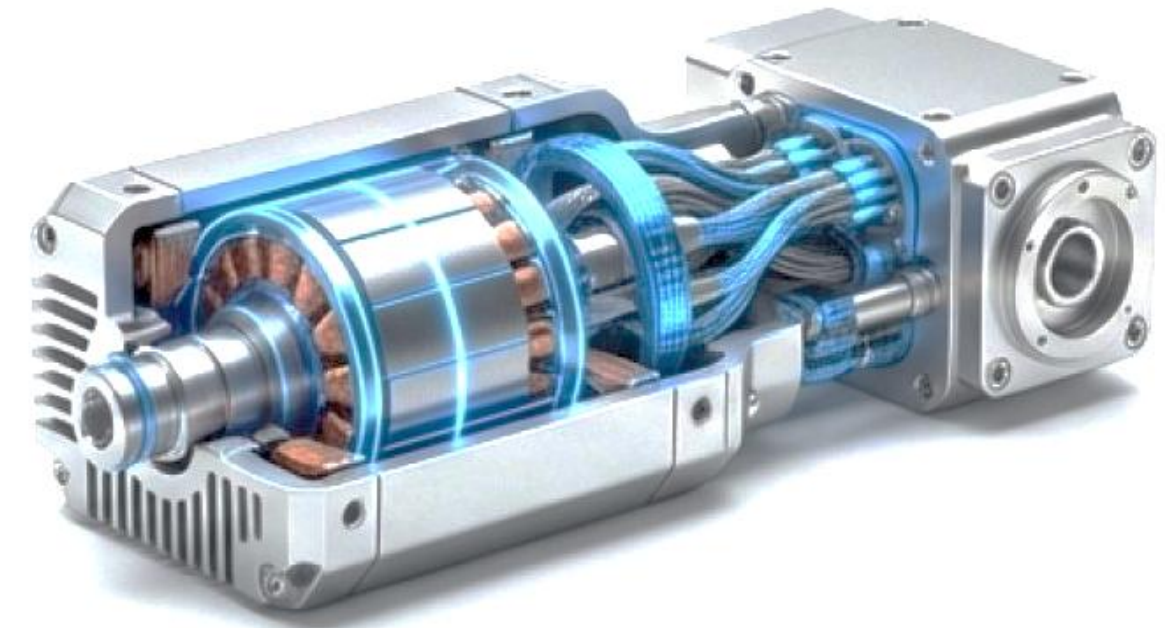

Platform-based enterprise built on key component modules

A critical milestone in strategic transformation

- **Unlocking diversified product application layouts**

AFM applications extend beyond robotics to high-end industrial and vehicle sectors. This enables Pan-International to enter markets for industrial cooling fans, data center thermal systems, and other advanced applications.

- **Signaling a strategic shift from wire harnesses to key components**

Not only optimizing product portfolio and gross margins but also transforming from a passive contract manufacturer into a collaborative partner providing core powertrain system solutions.



Pan-International's humanoid robotics strategic roadmap

Driver behind a Strategy Transformation

■ Integrator of group resources:

Since June 2023, Mr. Rase Lee has served as Chairman of Pan-International. He also oversees Foxconn Group's commercial EV segment and the C business group, covering precision molding, automation systems, robotics, and mechanical components.

■ Architect of supply chain upgrade:

Pan-International is transitioning from a traditional component manufacturer to an integrator of key high-value components. Leveraging over 30 years of expertise across production, R&D, and management, Rase is steering the company toward a more strategic and indispensable position within global supply chain.

■ Deep-Rooted within Foxconn:

Prior to joining Pan-International, Rase held senior leadership positions within the Foxconn group, including serving as chairman of Foxconn Technology (2354 TT).

Building a humanoid robotics value chain

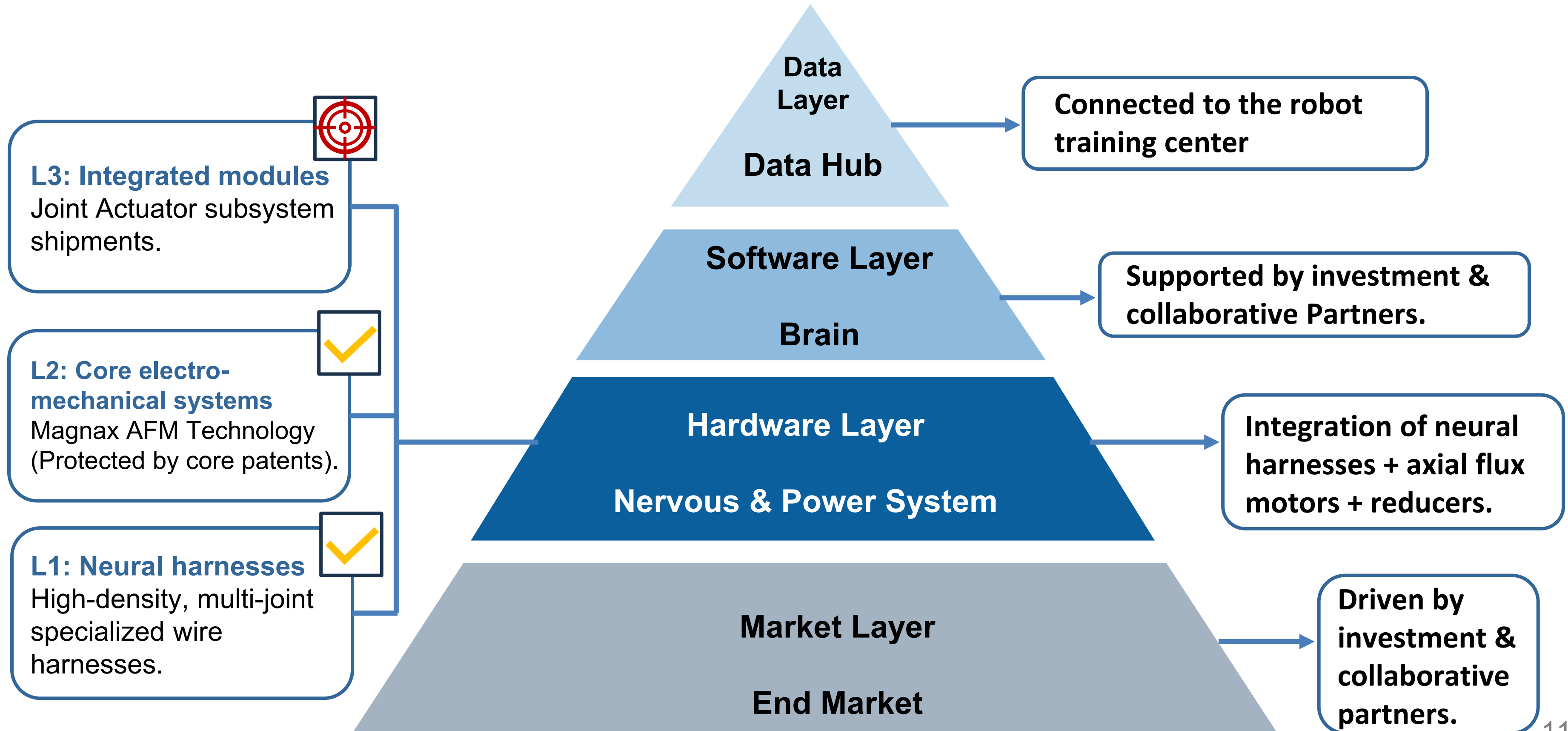

Hon Hai Group's Robotics Strategy Executor

Key strategy executor within Hon Hai group's robotics roadmap

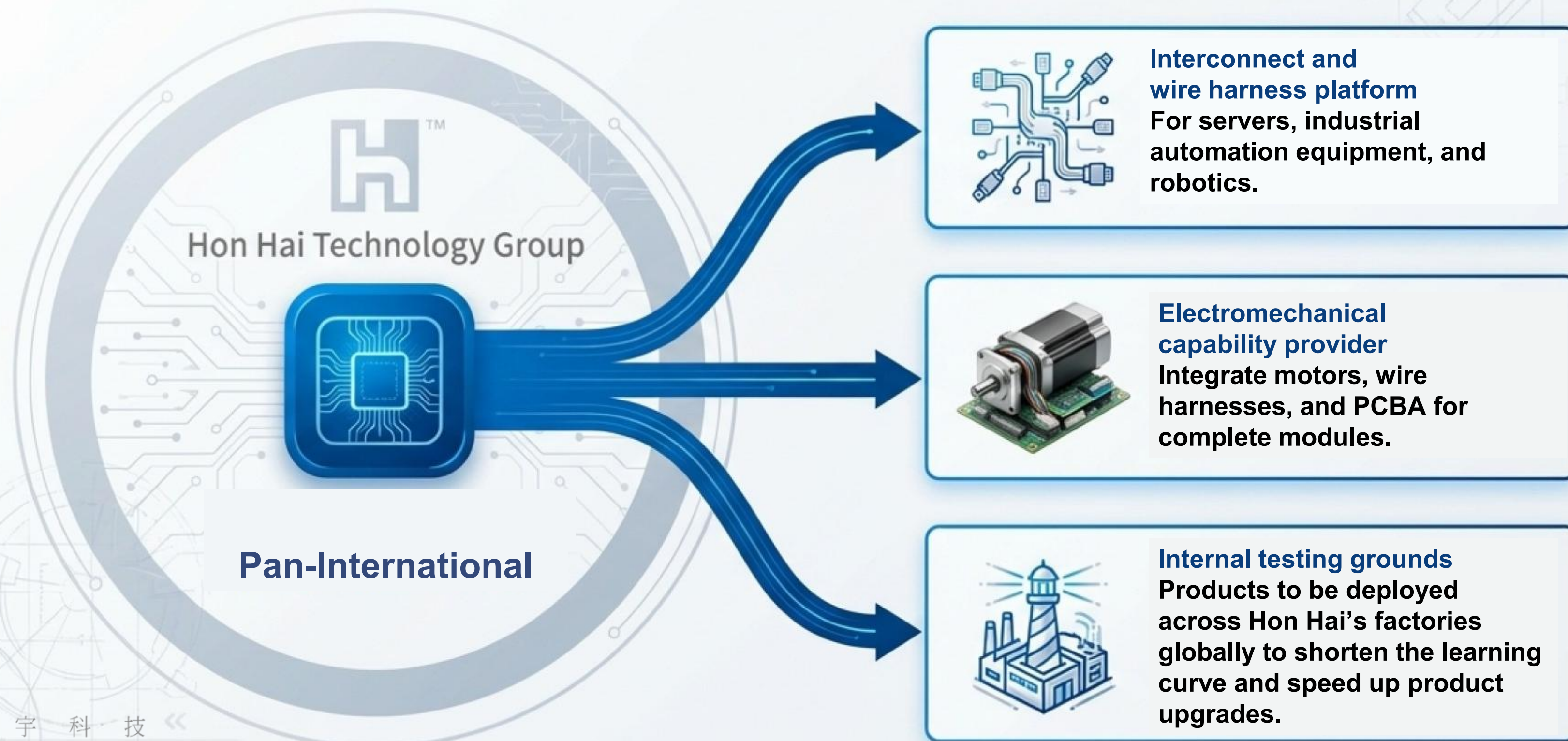

Stretch Competencies for Humanoid Opportunities

Collaborative robots (Cobots)



AGV & AMR

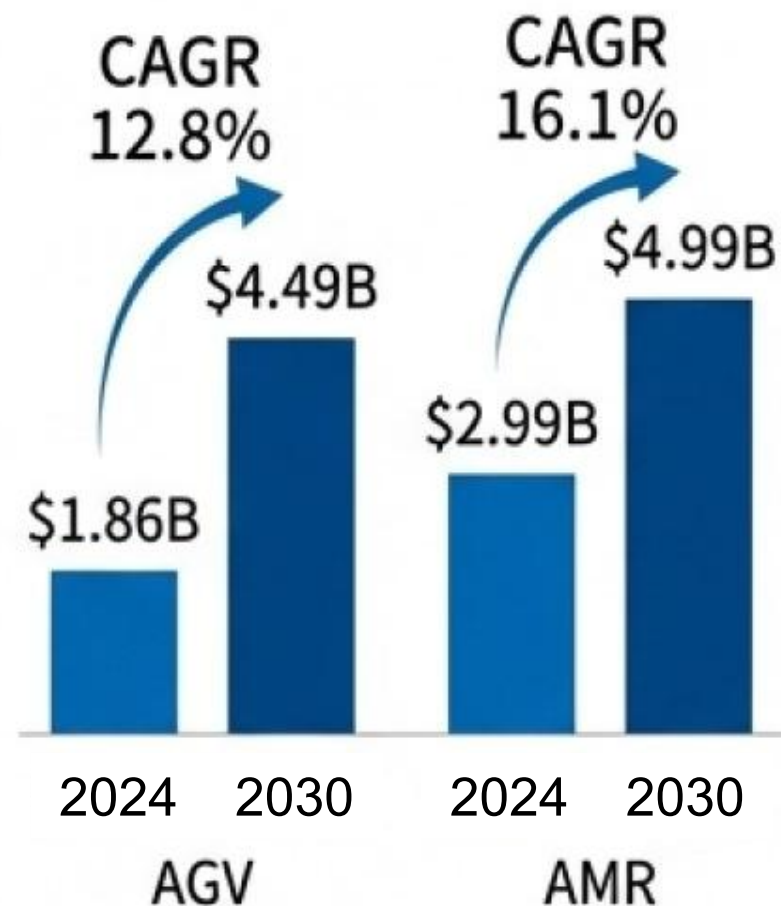

Humanoid robots

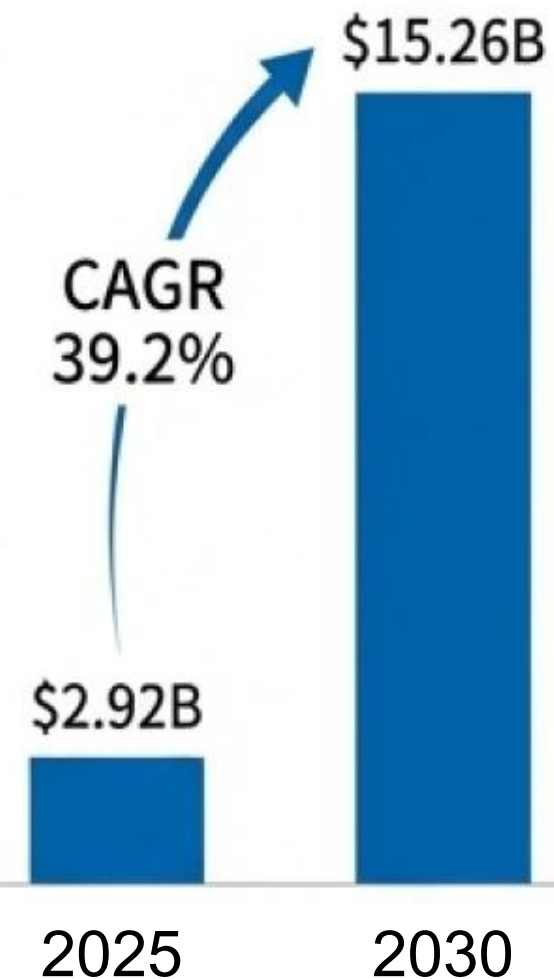

- Leveraging robotics wire harness technology to enter Cobot and AGV/AMR sectors
- Combining current capabilities with AFM for the humanoid key components
- Using key components to integrate the complete humanoid robotics ecosystem.



Moving up the value chain via 3S Strategy

Pan-International today: Half a century of manufacturing excellence



Leading provide of comprehensive components. Product includes **wire harnesses, connectors/enclosures, Printed Circuit Boards (PCBs), and full system assembly.**



NT\$ 21.8 Billion
2025 Revenue

NT\$ 23 Billion
Market Cap (2026/4/7)

Founded: **1971**

>10,000

Headquarter: **Taipei**

Global workforce

2025 Revenue breakdown

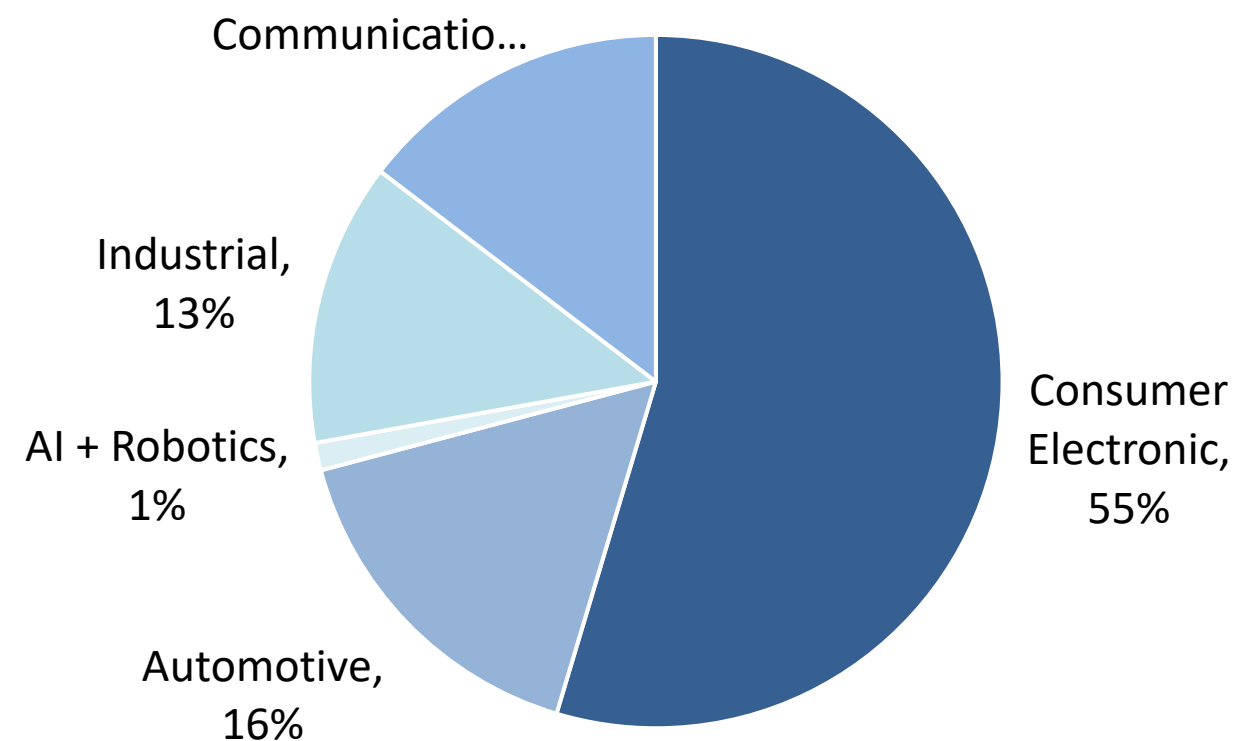

Global footprint

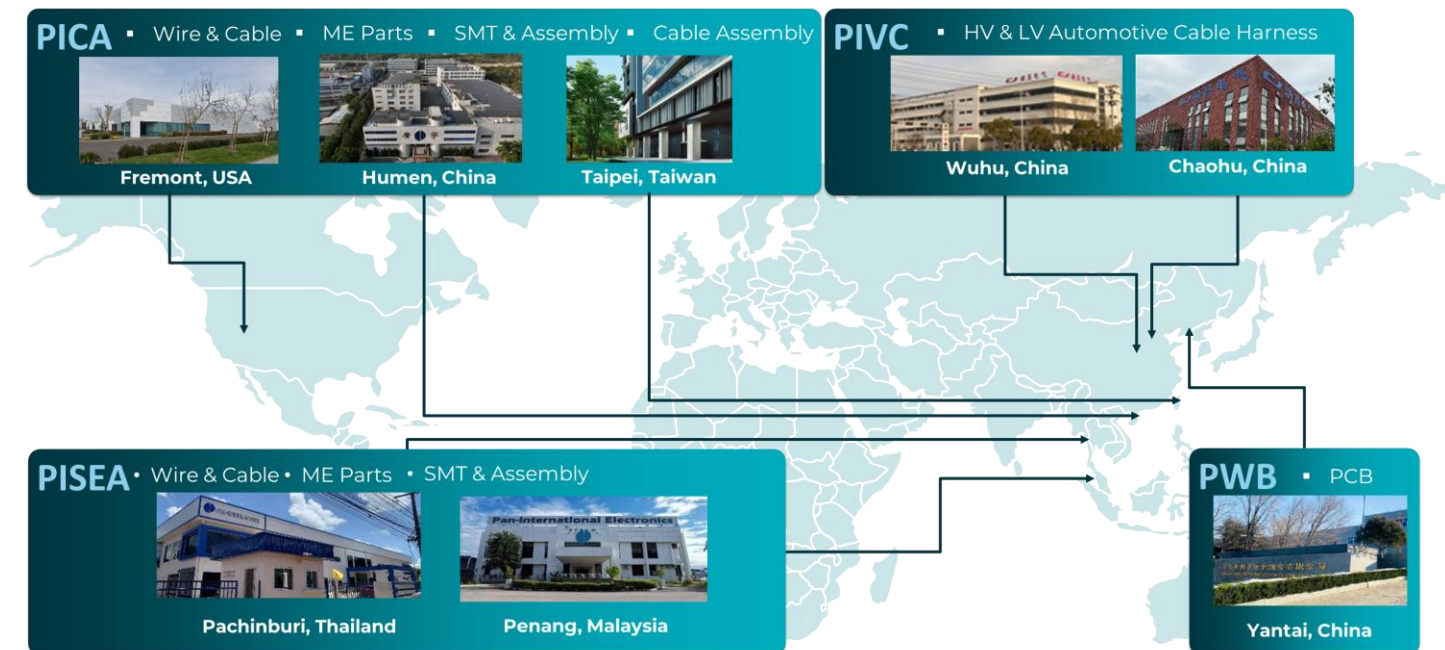

8 major bases in Taipei, Dongguan, Malaysia, Thailand, Anhui, Shandong, and California, USA.

Pan-International tomorrow: Building the future via 3S strategy



Stretch: Leveraging core platform technologies to power two major growth markets

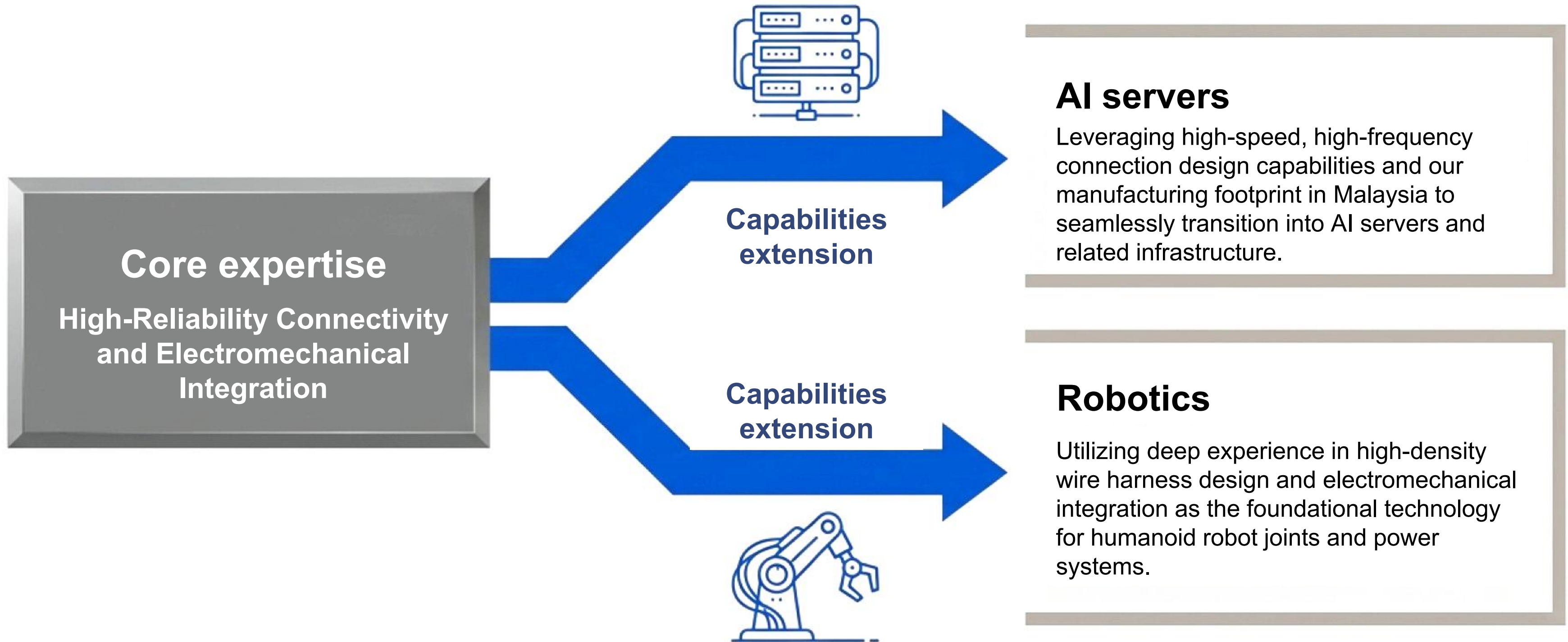

Shift: leveraging Malaysia's capacity layout to pivot toward the AI server market

Continued growth in AI demand and supply chain realignment

Growing computing power demand is driving server architecture upgrades. Meanwhile, global supply chain re-shape creates significant opportunities for manufacturers with a diversified global footprint.

Extending capacity advantages into the AI server sector

Building upon current capabilities and established manufacturing presence in Malaysia, Pan-International is increasing value-adds to AI infrastructure market

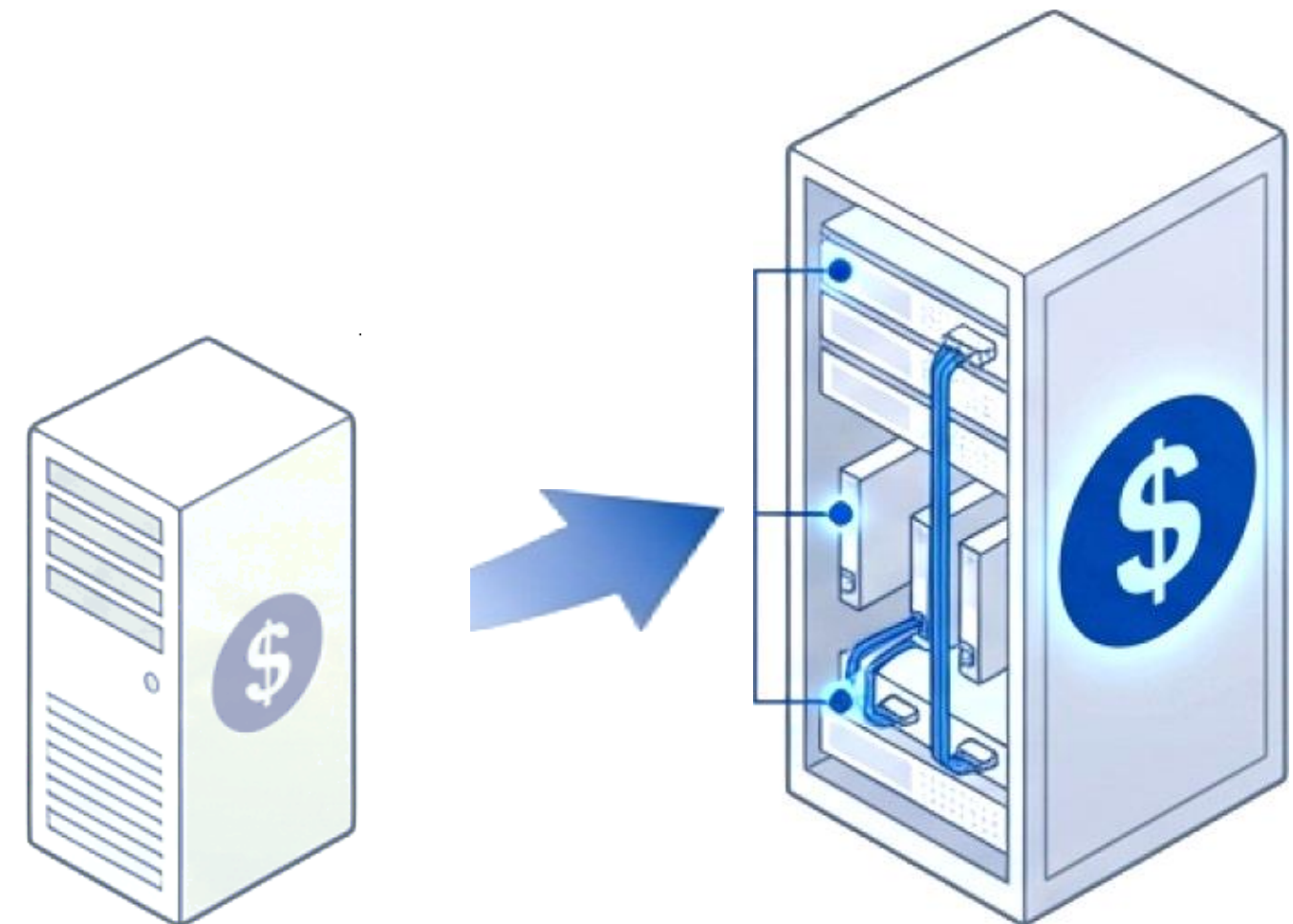

Scale: Building a humanoid robotics ecosystem from core components

Based on AFM core technology to develop a complete humanoid ecosystem.



Foundation of excellence:
half-century of precision manufacturing provides a solid foundation for developing key humanoid robot components.

Synergistic power:
AFM technology, combined with manufacturing prowess, accelerates the development of optimized power solutions for humanoid robots.

Ecosystem construction:
Move up the humanoid robotics value chain through investments, acquisitions, and strategic alliances to build a complete ecosystem

Strategic objectives and outlook

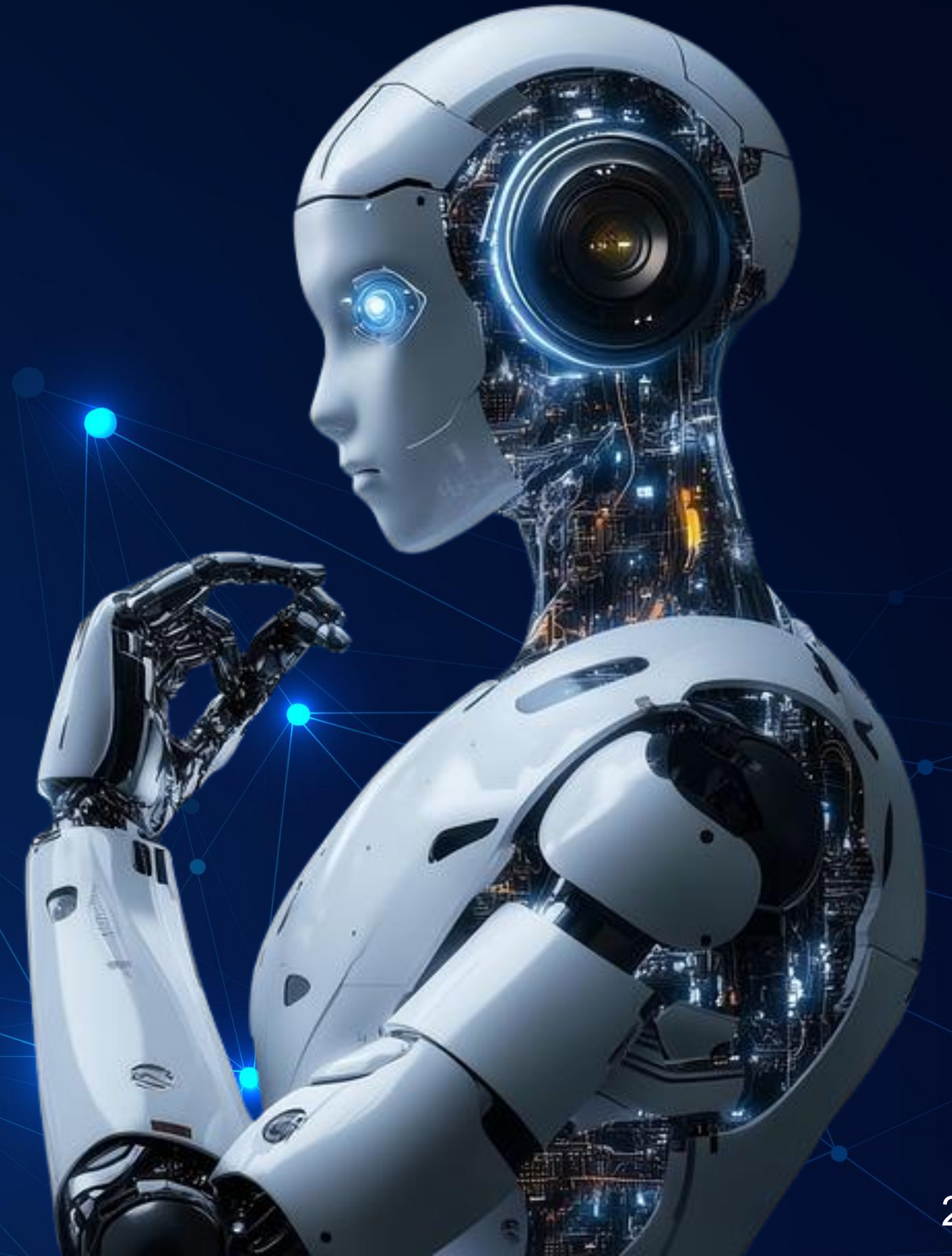

Journey of growth via strength: Key strategy actions



Leveraging core component technologies, Pan-International targets to supply **25–50%** of the humanoid robotics bill of material (BOM), driving significant revenue and earnings contributions from the robotics segment.

Humanoid business

Sample delivery of AGV & humanoid wire harnesses	Enter AGV market	Acquisition of AFM and Robotics Software Technology; Investing in robotic brands	Acquisition of critical reducer technology.	AFM products start contributing to revenue	AFM products begin profit contribution	Integration of upstream & downstream ecosystems	Significant revenue growth in key modules	Joint Entry into finished robot markets with strategic partners	Capitalization of robotics data assets
--	------------------	--	---	--	--	---	---	---	--

Ai server business

Malaysia plant begins mass production of AI servers	Explore other AI server components	Capture localized AI data center opportunities
---	------------------------------------	--

>5% global robotics market share & >50% new business contribution in 2030

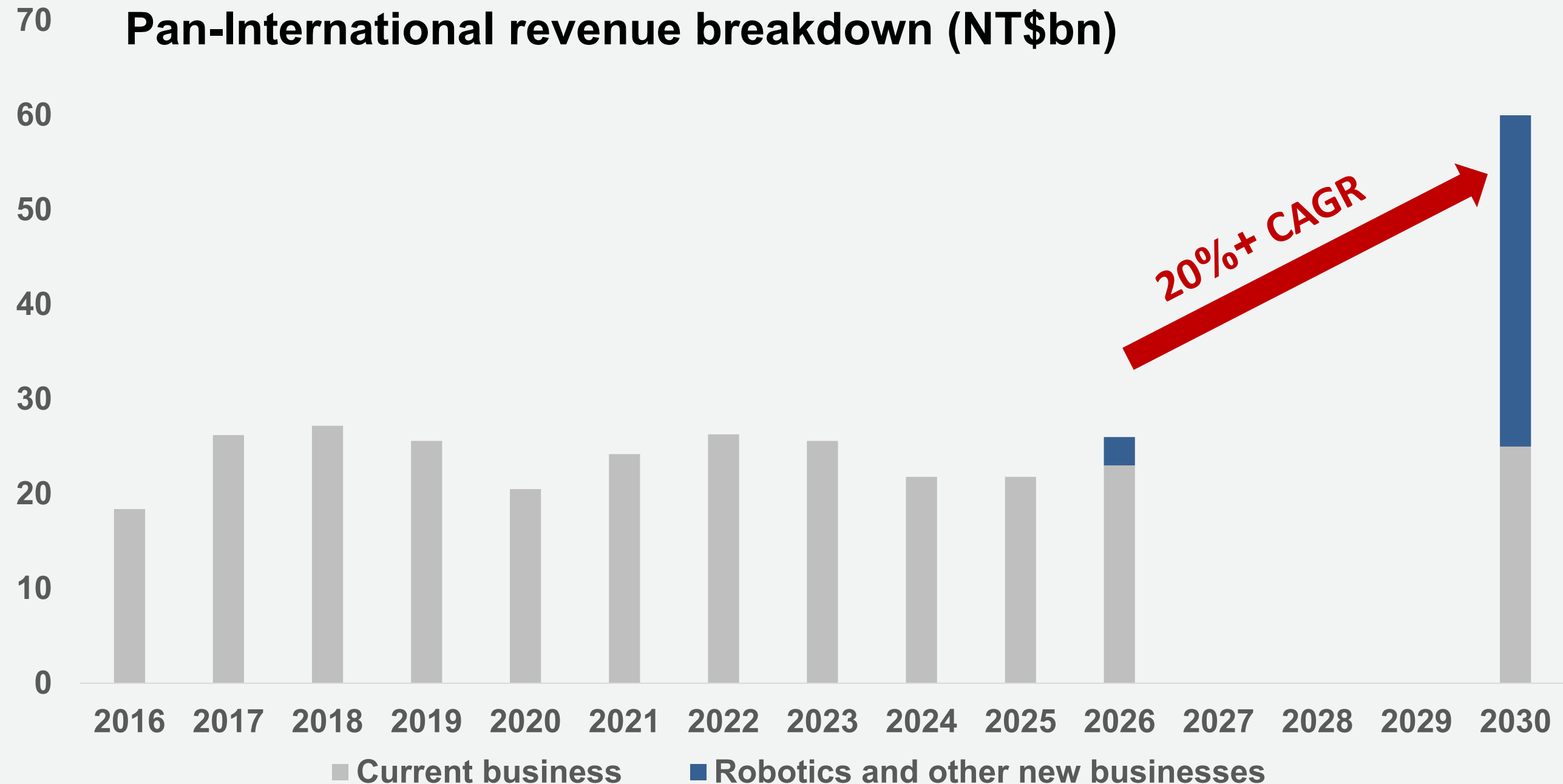

- Global market leadership:** Targeting a global market share of over 5% in the robotics sector. Based on US\$15bn market projection, robotics and other new businesses to contribute **more than 50%** of revenue and profit by 2030.
- Accelerating revenue:** Committed to **an average annual revenue growth rate (CAGR) of at least 20%**, driven by the scaling of these high-growth segments.

Maintaining a stable dividend payout ratio and yield

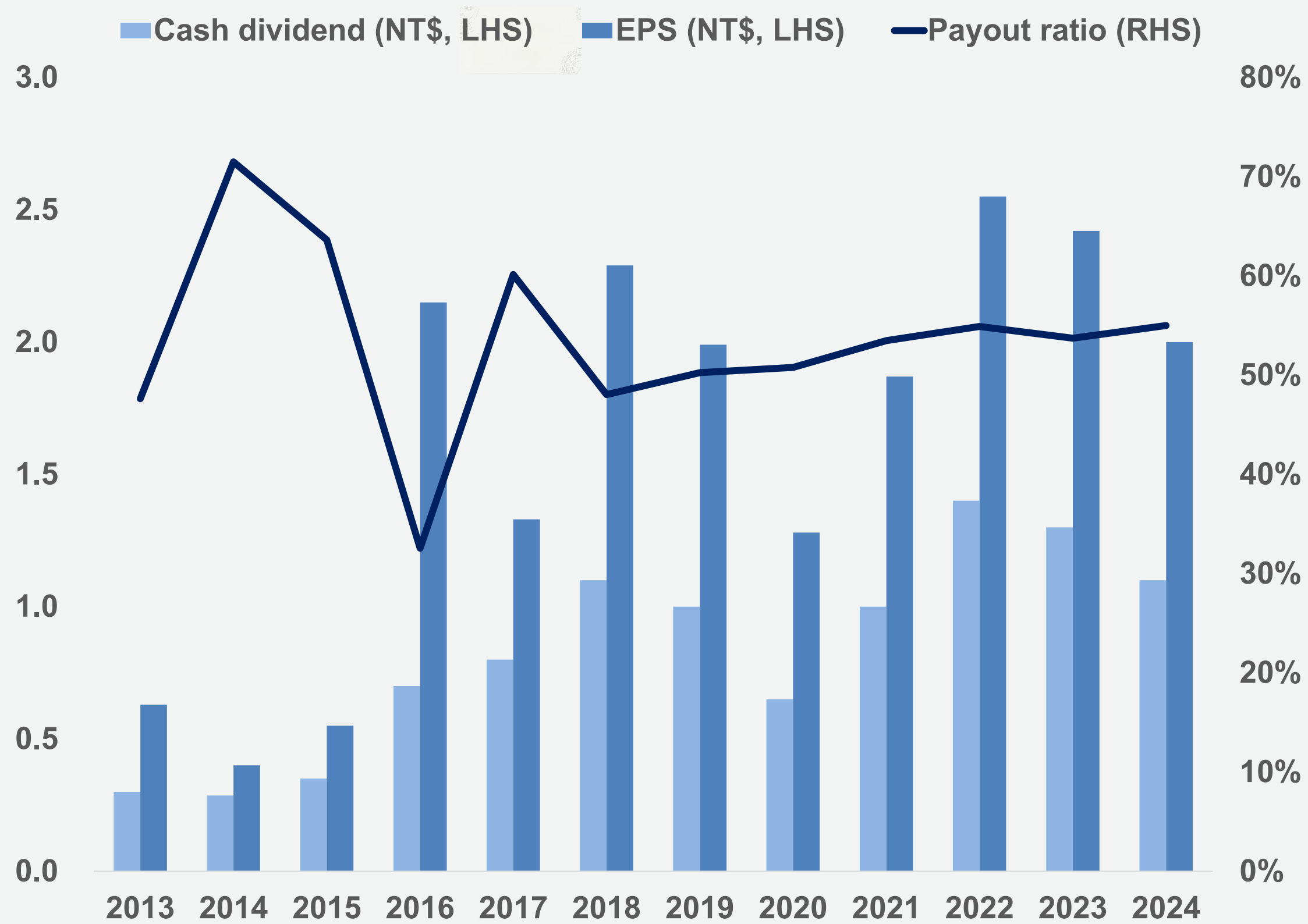

- Commitment to consistent payouts:** In recent years, Pan-International has remained dedicated to maintaining a cash dividend payout ratio of **at least 50%**.



廣 宇 科 技
Pan-International

**Shaping the future with Sincerity
and Innovation**

Thank you